

EXPEC Product Series



EXPEC 3500 Series GC-MS



SUPEC 7000 Series ICP-MS



EXPEC 5210 Series LC-MS/MS



Fully automatic heavy metal analysis system



EXPEC 6500 Series ICP-OES



EXPEC 1370/1330 Series NIR



SUPEC 5000 Series permanganate index

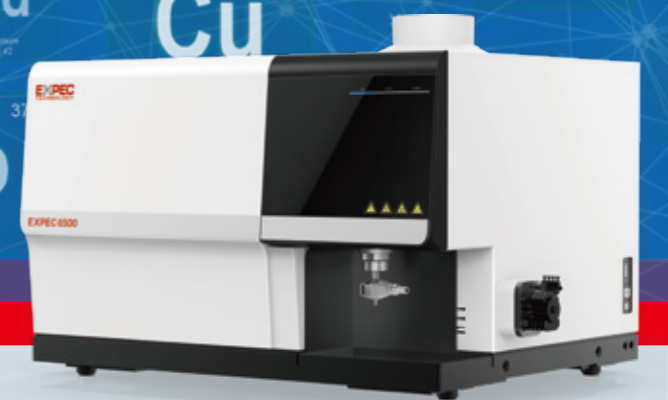

EXPEC 6500 ICP-OES

Exert our thoughts to specialize

Hangzhou EXPEC Technology Co., Ltd. Add: 2466-1
Keji Boulevard, Qingshanhu Sub-district,
Lin'an District, Hangzhou, Zhejiang Province 311300
Tel: +86-0571-85012185



EXPEC 6500

A new generation of full spectrum ICP-OES

EXPEC Technology adheres to the responsibility and mission of the "Future Laboratory Explorer". The company has created the new generation EXPEC6500 ICP-OES after years of technology accumulation and devotion in research and development, and made a new leap in core technologies such as RF power supplies, large area array detectors, and methods for observation with plasma torch flame. The ICP-OES supports the analysis of rare earths with requirements for full-spectrum high-resolution, and the analysis of Cl/Br elements over the deep ultraviolet waveband. At the same time, a variety of easy-to-use functions and intelligent auxiliary equipment have been developed to form an intelligent analysis system, which can help operators improve the efficiency, free them from complicated and repetitive tasks, and create value more effectively.



EXPEC 6500 Type ICP-OES



EXPEC 6000 Type ICP-OES



5000 Type ICP-OES

EXPEC 6500

Entirely new, entire spectrum; whatever thought of, attained.

The EXPEC 6500 inductively coupled plasma emission spectrometer adopts a newly developed vertical torch dual observation technology, which can measure elements of relatively large differences in content in a complex matrix. The patented self-excited all-solid-state RF power supply ensures that the system will have excellent adaptability to samples, and offers a low-power standby mode, which greatly reduces argon consumption. The unique large-area array high-sensitivity ECCD sensor brings better performance to the product. Combined with many years of experience of EXPEC series in spectroscopy instrument development, the EXPEC 6500 Type ICP-OES product offers the 8-hour stability index RSD of < 1%, and the precision RSD of twin internal standard method of < 0.1%, and thus brings you stable and reliable analysis results.

Main features of product

A new generation of vertical torch dual observation technology

The EXPEC 6500 product adopts a newly developed vertical torch dual observation technology, which greatly reduces argon consumption and torch consumption, and can be used to measure elements of relatively large differences in content in a complex matrix. The vertical torch prevents high salt deposition, and the radial observation avoids matrix interference, with which better sensitivity and repeatability can be achieved. The innovative vertical observation technology with adjustable height can optimize the observation position for different elements.

Patented self-excited all-solid-state RF power supply

The product integrates the self-excited all-solid-state RF power supply with EXPEC's third-generation patented technology to ensure that the equipment has better sample adaptability and stability. There won't be any flameout even if organic samples or even air is directly injected, thus eliminating the need for pre-treatment and preparation processes for organic samples such as oil products. The power range of the power supply is (500-1600) W, and its power adjustment range is better than that of most mainstream products. In the 500W low-power standby mode, the argon consumption is 5L/min, which adequately saves the cost of argon consumables for the user, and eliminates the waiting time required between the repeated turning on and off of the stable RF power supply.

The large area array ECCD sensor improves the sensitivity and spectral range of the instrument.

As for the proprietary large area array ECCD sensor, its excellent low noise and deep ultraviolet response combined with anti-overflow design, provide the EXPEC 6500 with good detection limits. The large area array design ensures that the instrument can truly acquire the full spectrum in one take, and finish analyzing 72 elements in 10 s.

8-hour stability RSD < 1%

Through high-precision temperature gradient field simulation, and air duct fluid dynamics simulation, in combination with repeated practical verification, the internal structure design has been optimized, which gives the structure greater resistance to environmental temperatures. Since the stability design of many key components such as RF power supply and injection system is incorporated into the instrument, the high stability of 8 hours RSD is below 1%, which has reached the leading level internationally.



EXPEC 6500

Exert our thoughts to specialize.

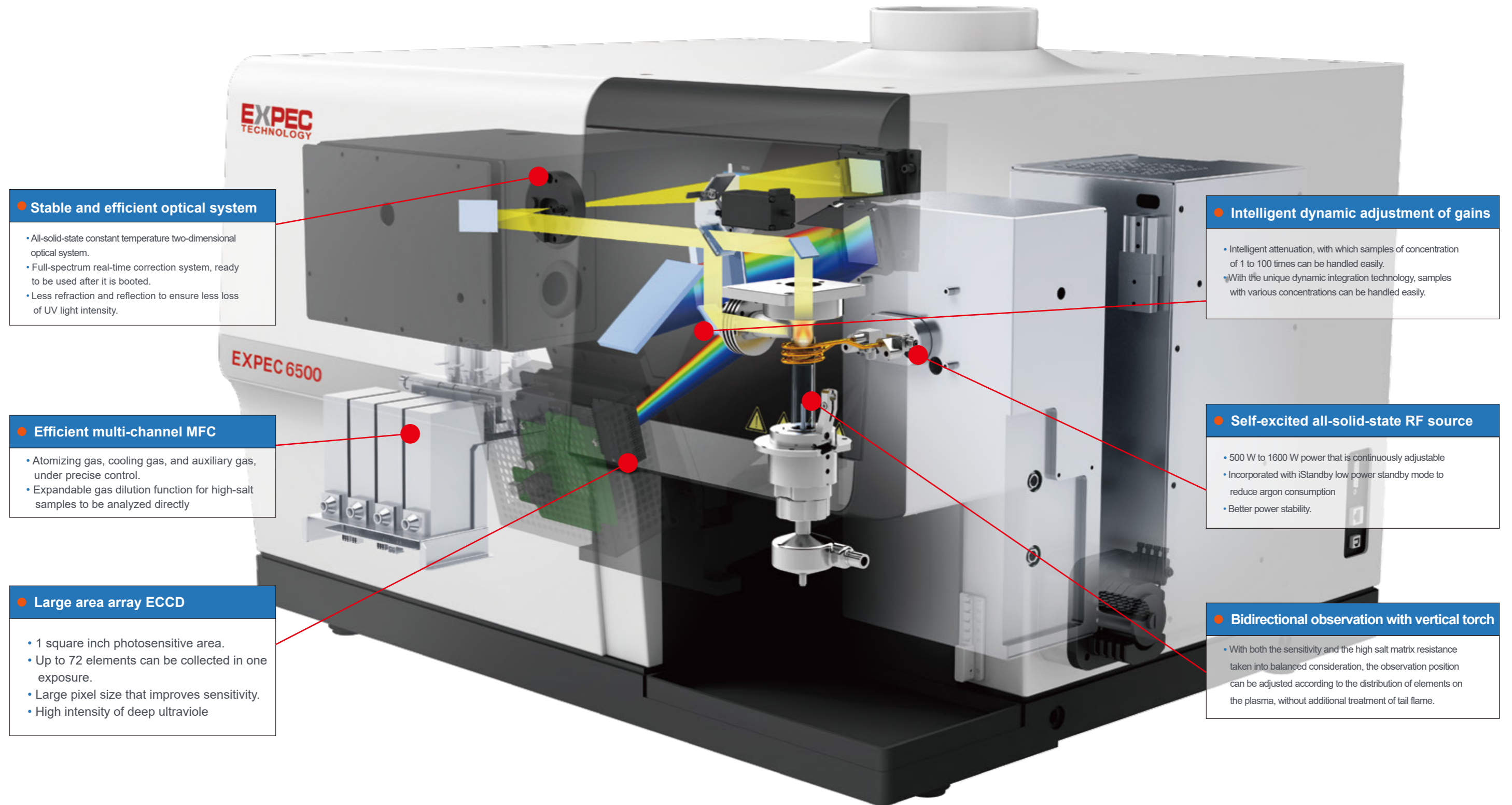

Stable and efficient optical system

- All-solid-state constant temperature two-dimensional optical system.
- Full-spectrum real-time correction system, ready to be used after it is booted.
- Less refraction and reflection to ensure less loss of UV light intensity.

Efficient multi-channel MFC

- Atomizing gas, cooling gas, and auxiliary gas, under precise control.
- Expandable gas dilution function for high-salt samples to be analyzed directly

Large area array ECCD

- 1 square inch photosensitive area.
- Up to 72 elements can be collected in one exposure.
- Large pixel size that improves sensitivity.
- High intensity of deep ultraviolet

Intelligent dynamic adjustment of gains

- Intelligent attenuation, with which samples of concentration of 1 to 100 times can be handled easily.
- With the unique dynamic integration technology, samples with various concentrations can be handled easily.

Self-excited all-solid-state RF source

- 500 W to 1600 W power that is continuously adjustable
- Incorporated with iStandby low power standby mode to reduce argon consumption
- Better power stability.

Bidirectional observation with vertical torch

- With both the sensitivity and the high salt matrix resistance taken into balanced consideration, the observation position can be adjusted according to the distribution of elements on the plasma, without additional treatment of tail flame.

All-digital self-excited all-solid-state RF power supply with iStandby mode

Fully digital power supply control: The RF power supply based on dual power supply technology is continuously adjustable over the wide power range of 500 W to 1600 W, with better sample adaptability.

- Self-excited RF power supply: The matching is quick, thus offering adaption to complex sample analysis and switching; there are no moving parts, which makes the instrument more reliable.
- iStandby mode: The mode enables the ultra-low power standby function, and reduces argon consumption by more than 50%.
- The water-cooled design enables rapid heat dissipation, and the power stability is within 0.1%, thus guaranteeing the reliability.

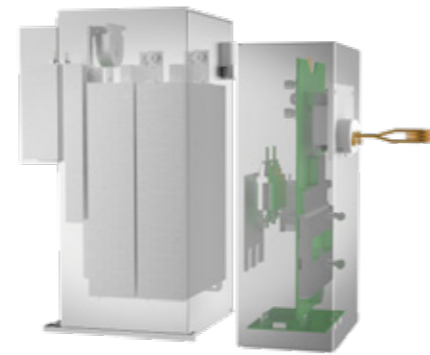

All-digital self-excited all-solid-state radio frequency power supply

Stable and efficient two-dimensional optical system with echelle grating

- Efficient two-dimensional spectroscopic system, with less reflection times and less light energy loss.
- Heat-balanced control light chamber at constant temperature of 36 degrees, as cornerstone of stable instrument.
- The distributed purge is designed based on fluid mechanics simulation, and enables the optical system to quickly establish a high-purity argon atmosphere, and thus realizes the ultraviolet analysis, and save both the time and argon.
- The thermal isolation design of the host and the optical system balances the heat exchange, makes the optical system better resistant to the influence of changes in the external environment.
- Applications on vehicles are supported in a stable and reliable way.

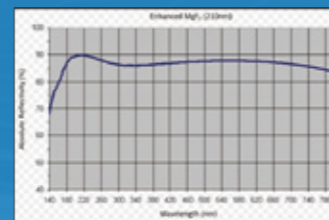
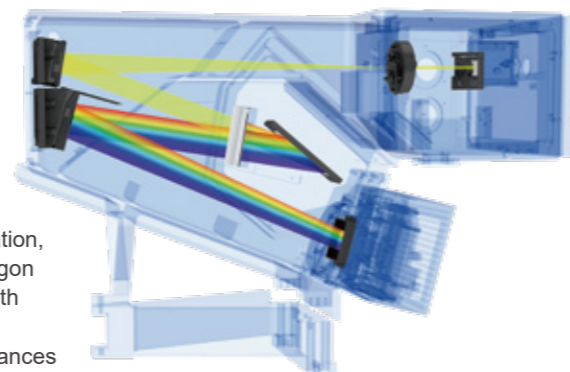

Lens reflection efficiency chart

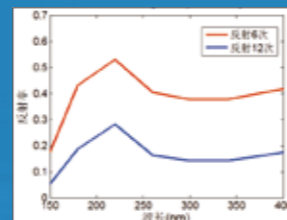

Comparison chart of efficiency of multiple reflections

Proprietary high-performance large area array ECCD

• square inch large area array CCD detector

The pixel size is large, which brings about high-sensitivity response, and the overall area is large, with which a wider spectral range can be obtained while the high resolution is maintained.

• 1024*1024 pixels, one-time exposure

Realization of detection of 72 elements in range of 165 nm to 900 nm, and obtainment of results in 10 s.

• Obvious hierarchy of deep ultraviolet zone has, and high sensitivity

• Back-vented anti-overflow design, with no need for worries about the influence of spectral line saturation on adjacent spectral lines

• TEC refrigeration packaged inside the sensor that directly acts on the pixel

Integrated, efficient, and highly reliable, and more conducive to eliminating influence of thermal noise.

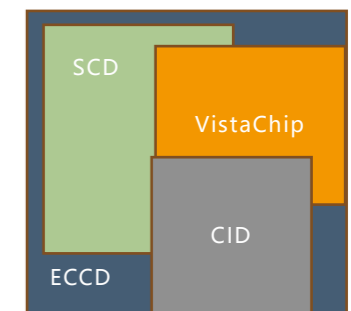
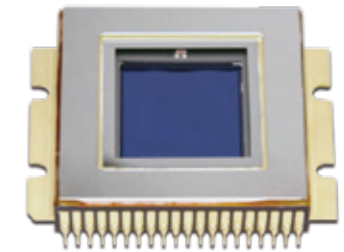

• Back-vented anti-overflow design

- Even in the 800 nm to 900 nm waveband where the argon line overflow is strong, the spectrum of effective elements can still be clearly distinguished.

• Good UV response

- The intensity of C and Al spectral lines around 165 nm is good.
- The ultraviolet waveband hierarchy is clearly visible.

EXPEC 6500

Refinement in the details

New generation of dual observation technology with vertical torch

- The vertical torch reduces argon consumption, and prevents high salt deposition.
- The vertical torch prolongs the service life of the torch, and reduces the consumption of torch consumables.
- Axial observation: High sensitivity.
- Radial observation: The interference by matrix is prevented. The position of plasma light can be adjusted. And the element acquisition can be optimized according to different positions of the plasma.
- Bidirectional observation: Having the advantages of both (axial and radial), and outperforming both.



The patented real-time drift correction technology corrects the spectral positions.

- Only C, N, and Ar spectral lines are used for start-up and ignition, and the spectrum correction is automatically completed without specific sample injection.
- The patented full-spectrum real-time correction (FSC) technology uses the characteristic line of the non-interfering neon to correct the subtle deviations of the spectrum in real time, so that better spectral integration can be achieved to ensure good long-term stability.

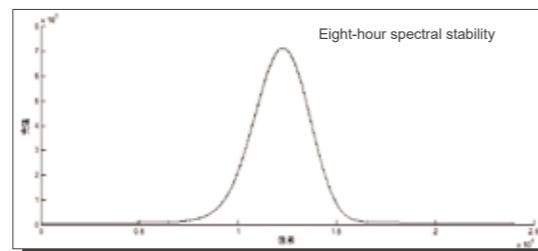
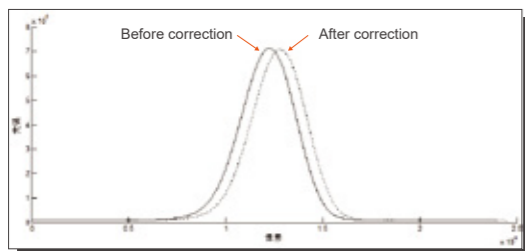

Intelligent dynamic gain adjustment "triple hit", easy control over any concentration gradient

- **Intelligent attenuation, with which samples of concentration of 1 to 100 times can be handled easily**

The attenuation multiple is automatically increased according to the high and low concentration of elements to complete the analysis of a sample with a steep gradient of the elements of high and low concentrations at one time without repeated dilution, which reduces the difficulty of sample pretreatment

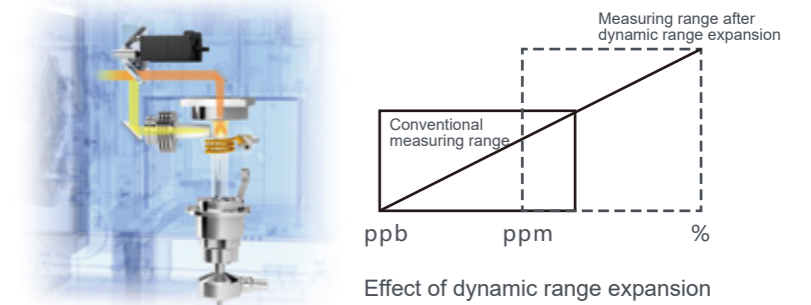

- **Smart integration**

Patented intelligent integration design: Signals and background are acquired at synchronously; the exposure time depends on the light intensity of the spectrum; the best exposure time of the spectrum is calculated automatically; the light intensity is normalization calculated; the working curve is combination calculated; the integration time control is accurate to the microsecond; the dynamic range is widened; and the repeated dilution of the sample is avoided.

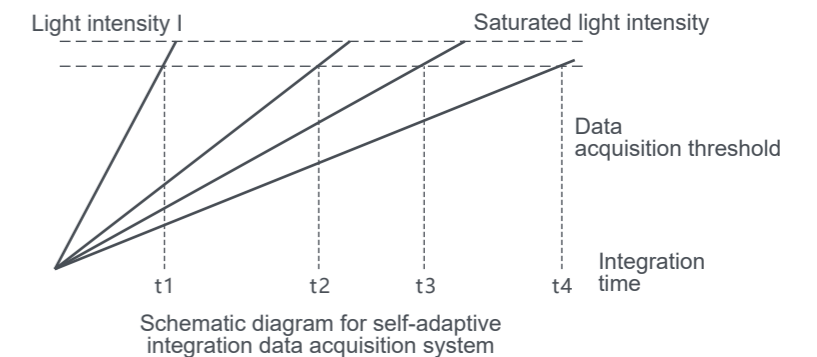

- **Argon online dilution**

Effective dilution of high salt samples of more than 10% is achieved by adding a channel of argon gas for dilution which is controlled by MFC before the aerosol in the atomization chamber enters the torch, and the difficulty of sample pretreatment is thus reduced.



Schematic diagram for argon dilution input

Seamless expansion takes you into another experimental world with ease.

The software interface is friendly and easy to use.

Stable injection system

- Multi-channel digital mass flow controller, providing precise control over each channel of argon, with the control accuracy at 0.01 L/min, to ensure the stability of the data measured.
- The high-precision 12-rotor 4-channel peristaltic pump ensures stable sample injection, and can add internal standard solution and standard addition solution according to the needs, which is conducive to complex sample analysis.
- Fully split-body torch, the installation of which is self-collimating; for different applications, only the center tube needs to be replaced, which greatly reduces costs.

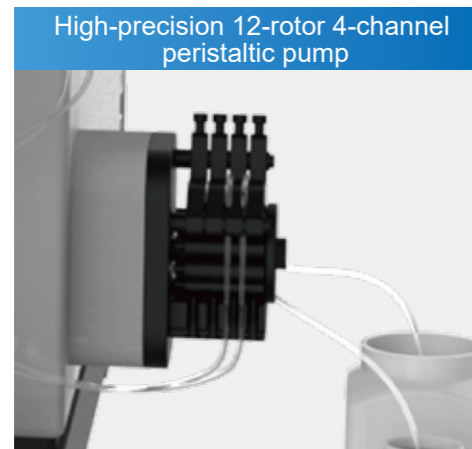

Real-time display of status information

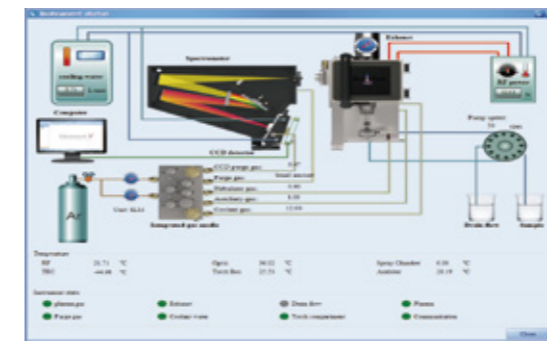

Windows-style operation interface

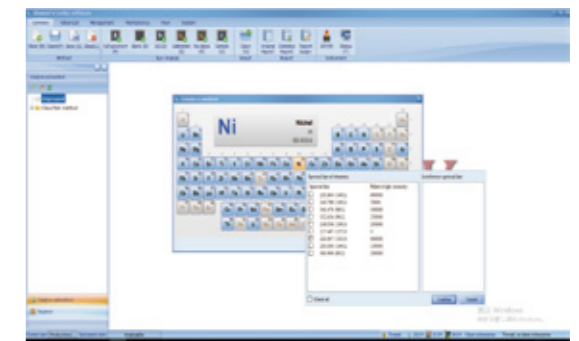

Method backup and import

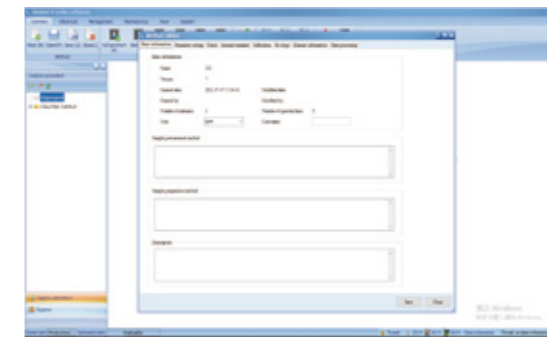

Full spectrum and sub-array controls

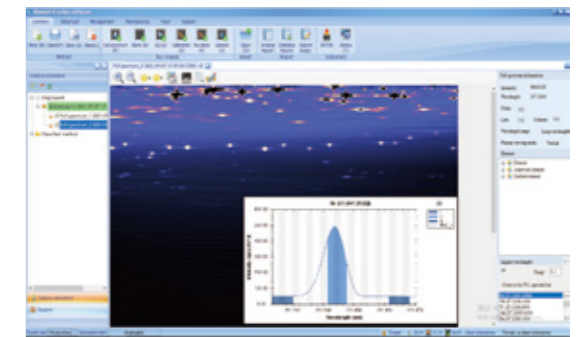

Supporting expansion with a variety of accessories



Model	Features	Applicable field
EXPEC 6500 Type D	Bidirectional observation with vertical torch	Applicable to areas with high sensitivity requirements, and providing a relatively wide range of versatility.
EXPEC 6500 Type R	Bidirectional observation with vertical torch	Suitable for applications with complex matrices, such as metals, oil products, geological and mineral samples, and etc.